



P500P2/P550E2



Image for illustration purposes only.

Generating Set Model	Prime*	Standby*
380-415V,50Hz	500.0 kVA / 400.0 kW	550.0 kVA / 440.0 kW
	- / -	- / -

Ratings at 0.8 power factor.

Prime Rating

These ratings are applicable for supplying continuous electrical power (at variable load) in lieu of commercially purchased power. There is no limitation to the annual hours of operation and this model can supply 10% overload power for 1 hour in 12 hours.

Standby Rating

These ratings are applicable for supplying continuous electrical power (at variable load) in the event of a utility power failure. No overload is permitted on these ratings. The alternator on this model is peak continuous rated (as defined in ISO 8528-3).

Standard Reference Conditions

Note: Standard reference conditions 25°C (77°F) Air Inlet Temp, 100m (328 ft) A.S.L. 30% relative humidity.
 Fuel consumption data at full load with diesel fuel with specific gravity of 0.85 and conforming to BS2869: 1998, Class A2.

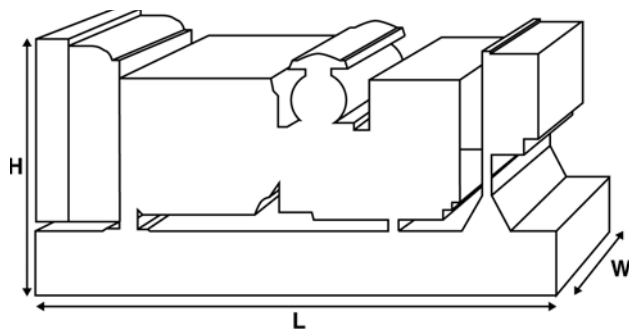

Ratings and Performance Data		
Engine Make & Model:	Perkins 2506C-E15TAG2	
Alternator manufactured for FG Wilson by:	Leroy Somer	
Alternator Model:	LL6114F	
Control Panel:	PowerWizard 1	
Base Frame:	Heavy Duty Fabricated Steel	
Circuit Breaker Type:	3 Pole MCCB	
Frequency:	50 Hz	60 Hz
Engine Speed: RPM	1500	-
Fuel Tank Capacity: litres (US gal)	928 (245.2)	
Fuel Consumption: l/hr (US gal/hr)		
(100% Load)	- Prime	102.4 (27.1)
	- Standby	111.8 (29.5)

Available Options

FG Wilson offer a range of optional features to tailor our generating sets to meet your power needs. Options include:

- Upgrade to CE Certification
- A wide range of Sound Attenuated Enclosures
- A variety of generating set control and synchronising panels
- Additional alarms and shutdowns
- A selection of exhaust silencer noise levels

For further information on all of the standard and optional features accompanying this product please contact your local Dealer or visit: www.FGWilson.com

Dimensions and Weights

Length (L)	Width (W)	Height (H)	Dry	Wet
mm (in)	mm (in)	mm (in)	kg (lb)	kg (lb)
3700 (145.7)	1100 (43.3)	2143 (84.4)	3920 (8642)	3958 (8726)
Dry = With Lube Oil		Wet = With Lube Oil and Coolant		

Ratings in accordance with ISO 8528, ISO 3046, IEC 60034, BS5000 and NEMA MG-1/22. Generating set pictured may include optional accessories.

Engine Technical Data		
No. of Cylinders / Alignment:	6 / In Line	
Cycle:	4 Stroke	
Bore / Stroke: mm (in)	135.0 (5.3)/167.0 (6.6)	
Induction:	Turbocharged Air To Air Charge Cooled	
Cooling Method:	Water	
Governing Type:	Electronic	
Governing Class:	ISO 8528 G2	
Compression Ratio:	16.0:1	
Displacement: l (cu. in)	15.2 (927.6)	
Moment of Inertia: kg m ² (lb/in ²)	4.29 (14660)	
Engine Electrical System:		
- Voltage / Ground	24/Negative	
- Battery Charger Amps	70	
Weight: kg (lb)	- Dry	1633 (3600)
	- Wet	1714 (3779)

Performance	50 Hz	60 Hz
Engine Speed: rpm	1500	-
Gross Engine Power: kW (hp)		
- Prime	443.0 (594.0)	-
- Standby	487.0 (653.0)	-
BMEP: kPa (psi)		
- Prime	2471.0 (358.4)	-
- Standby	2717.0 (394.0)	-

Fuel System					
Fuel Filter Type:	Replaceable Element				
Recommended Fuel:	Class A2 Diesel				
Fuel Consumption: l/hr (US gal/hr)					
	110%	100%	75%	50%	
Prime	Load	Load	Load	Load	
50 Hz	111.8 (29.5)	102.4 (27.1)	78.4 (20.7)	53.4 (14.1)	
60 Hz	-	-	-	-	
	110%	100%	75%	50%	
Standby	Load	Load	Load	Load	
50 Hz		111.8 (29.5)	85.7 (22.6)	58.4 (15.4)	
60 Hz		-	-	-	

(Based on diesel fuel with a specific gravity of 0.84 and conforming to BS2869, Class A2)

Air Systems	50 Hz	60 Hz
Air Filter Type:	Paper Element 18"	
Combustion Air Flow: m ³ /min (cfm)		
- Prime	30.5 (1077)	-
- Standby	32.0 (1130)	-
Max. Combustion Air Intake Restriction: kPa (in H ₂ O)	6.2 (24.9)	-

Cooling System	50 Hz	60 Hz
Cooling System Capacity: l (US gal)	38.3 (10.1)	-
Water Pump Type:	Centrifugal	
Heat Rejected to Water & Lube Oil:		
kW (Btu/min)	- Prime 157.0 (8928)	-
	- Standby 179.0 (10180)	-
Heat Radiation to Room: Heat radiated from engine and alternator		
kW (Btu/min)	- Prime 63.0 (3583)	-
	- Standby 71.0 (4038)	-
Radiator Fan Load: kW (hp)	16.0 (21.5)	-
Radiator Cooling Airflow: m ³ /min (cfm)	660.0 (23308)	-
External Restriction to Cooling Airflow: Pa (in H ₂ O)	125 (0.5)	-

Cooling system designed to operate in ambient conditions up to 50°C (122°F). Contact your local FG Wilson Dealer for power ratings at specific site conditions.

Lubrication System	
Oil Filter Type:	Eco, Full Flow
Total Oil Capacity: l (US gal)	62.0 (16.4)
Oil Pan: l (US gal)	53.0 (14.0)
Oil Type:	API CI4 15W-40
Oil Cooling Method:	Water

Exhaust System	50 Hz	60 Hz
Silencer Type:	Industrial	
Silencer Model & Quantity:	SD150 (1)	
Pressure Drop Across Silencer System: kPa (in Hg)	0.28 (0.083)	-
Silencer Noise Reduction Level: dB	15	-
Maximum Allowable Back Pressure: kPa (in Hg)	6.8 (2.0)	-
Exhaust Gas Flow: m ³ /min (cfm)		
- Prime	81.0 (2860)	-
- Standby	87.0 (3072)	-
Exhaust Gas Temperature: °C (°F)		
- Prime	514 (957)	-
- Standby	528 (982)	-

General Information

Documentation

A full set of operation and maintenance manuals and circuit wiring diagrams.

Generating Set Standards

The equipment meets the following standards: BS5000, ISO 8528, ISO 3046, IEC 60034, NEMA MG-1.22.

FG Wilson is a fully accredited ISO 9001 company.

EU Stage II Emissions Compliant.

Warranty

All prime equipment carries a one year manufacturer's warranty. Standby equipment, limited to 500 running hours per year, has a two year manufacturer's warranty. For details on warranty cover please contact your local Dealer, or visit our website: FGWilson.com.

Dealer contact details: