

Model: C400D5EB
 Frequency: 50
 Fuel type: Diesel

Spec sheet:	EMERS-5888-EN
Noise data sheet (open/enclosed):	ND50-OS550/ND50-CS550
Airflow data sheet:	AF50-550
Derate data sheet (open/enclosed):	DD50-OS550/DD50-CS550
Transient data sheet:	TD50-550

Fuel consumption	Standby kVA (kW)				Prime kVA (kW)			
	1/4	1/2	3/4	Full	1/4	1/2	3/4	Full
Ratings	400 (320)				364 (291)			
Load	1/4	1/2	3/4	Full	1/4	1/2	3/4	Full
Gal (UK)/hr	7.3	12.2	16.2	20	7.1	11.5	15.3	18.5
L/hr	33.1	55.3	73.5	90.7	32.3	52	69.2	84.1

Engine	Standby Rating	Prime Rating
Engine manufacturer	Cummins	
Engine model	QSZ13-G7	
Configuration	4 cycle; in-line 6 cylinder diesel	
Aspiration	Turbocharged and charge air cooled	
Gross engine power output, kWm	419	366
BMEP at set rated load, kPa	2578	2252
Bore, mm	130	
Stroke, mm	163	
Rated speed, rpm	1500	
Piston speed, m/s	8.1	
Compression ratio	17:1	
Lube oil capacity, L	64	
Overspeed limit, rpm	1500 ±10%	
Regenerative power, kW	33	
Governor type	Electronic	
Starting voltage	24 Volts DC	

Fuel flow	
Maximum fuel flow, L/hr	247
Maximum fuel inlet restriction, mm Hg	202
Maximum fuel inlet temperature, °C	71

Air	Standby Rating	Prime Rating
Combustion air, m ³ /min	29.9	28.6
Maximum air cleaner restriction, kPa	3.2 – 6.2	

Exhaust

Exhaust gas flow at set rated load, m ³ /min	34.0	31.9
Exhaust gas temperature, °C	513	491
Maximum exhaust back pressure, kPa	13	

Standard set-mounted radiator cooling

Ambient design, °C	50	
Fan load, kW _m	18.5	
Coolant capacity (with radiator), L	62	
Cooling system air flow, m ³ /sec @ 12.7 mmH ₂ O	8.1	
Total heat rejection, Btu/min	16700	13700
Maximum cooling air flow static restriction mm H ₂ O	25.4	

Weights*

	Open	Enclosed
Unit dry weight kgs	3884	4966
Unit wet weight kgs	4669	5751

* Weights represent a set with standard features. See outline drawing for weights of other configurations.

Dimensions

	Length	Width	Height
Standard open set dimensions mm	3376	1500	2192
Enclosed set standard dimensions mm	5093	1564	2446

Genset outline

Open set

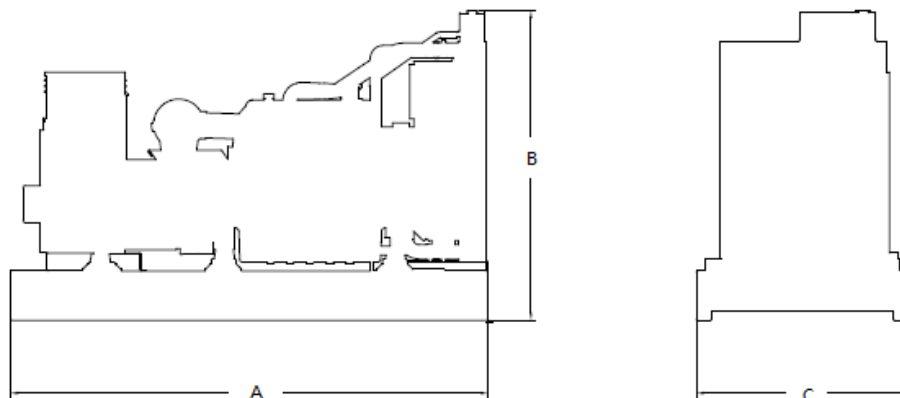

Enclosed set

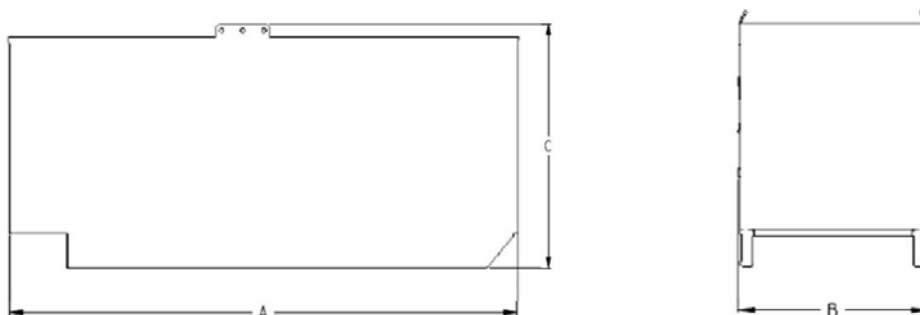

Outlines are for illustrative purposes only. Please refer to the genset outline drawing for an exact representation of this model.

Alternator data

Connection ¹	Temp rise °C	Duty ²	Alternator	Voltage
Wye, 3-phase	163/105 C	S/P	HC5C	380-440V
Wye, 3-phase	163/105 C	S/P	HC5C	190-220V

Ratings definitions

Emergency standby power (ESP):	Limited-time running power (LTP):	Prime power (PRP):	Base load (continuous) power (COP):
Applicable for supplying power to varying electrical load for the duration of power interruption of a reliable utility source. Emergency Standby Power (ESP) is in accordance with ISO 8528. Fuel Stop power in accordance with ISO 3046, AS 2789, DIN 6271 and BS 5514.	Applicable for supplying power to a constant electrical load for limited hours. Limited Time Running Power (LTP) is in accordance with ISO 8528.	Applicable for supplying power to varying electrical load for unlimited hours. Prime Power (PRP) is in accordance with ISO 8528. Ten percent overload capability is available in accordance with ISO 3046, AS 2789, DIN 6271 and BS 5514.	Applicable for supplying power continuously to a constant electrical load for unlimited hours. Continuous Power (COP) is in accordance with ISO 8528, ISO 3046, AS 2789, DIN 6271 and BS 5514.

Formulas for calculating full load currents:

$$\frac{\text{Three phase output}}{\text{Voltage} \times 1.73 \times 0.8} = \frac{\text{kW} \times 1000}{\text{Voltage} \times 1.73 \times 0.8}$$

$$\frac{\text{Single phase output}}{\text{Voltage}} = \frac{\text{kW} \times \text{SinglePhaseFactor} \times 1000}{\text{Voltage}}$$

See your distributor for more information.

Advanced Diesel Engineering
 14 Langthwaite Business Park,
 South Kirkby, Pontefract,
 WF9 3AP, UK
 Telephone: +44 (0) 1977 658 100
 Fax: +44 (0) 1977 608 111
 Email: enquiries@adeltd.co.uk
 Web: www.adeltd.co.uk

